

# CP

## 多連チャックパレット

Multiple chuck pallets



松本機械工業株式会社  
MATSUMOTO MACHINE CO., LTD.  
<https://mmkchuck.com>

〒920-0059 石川県金沢市示野町二80  
Ni-80 Shimeno-Machi Kanazawa, 920-0059 Japan  
Phone +81-(0)76-267-3211  
E-mail [sales@mmkchuck.com](mailto:sales@mmkchuck.com)  
ServiceCenter/Tokyo/Osaka/Nagoya/Tohoku  
Chicago, USA/Lyon, France

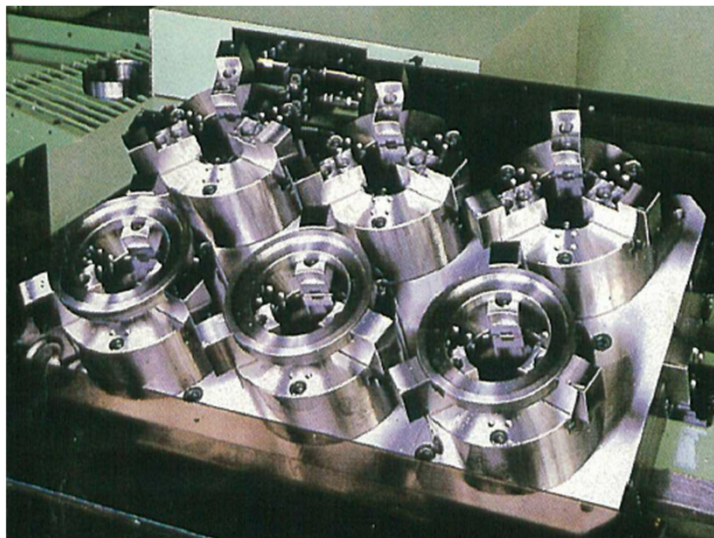

◆ **STC、SGXなどの定置型パワーチャックを多数個取り付ける治具プレートです。**

A jig plate for mounting a large number of stationary power chucks such as STC and SGX.

◆ **マシニングセンタの長時間加工に最適です。**

Ideal for long-time machining of machining centers.

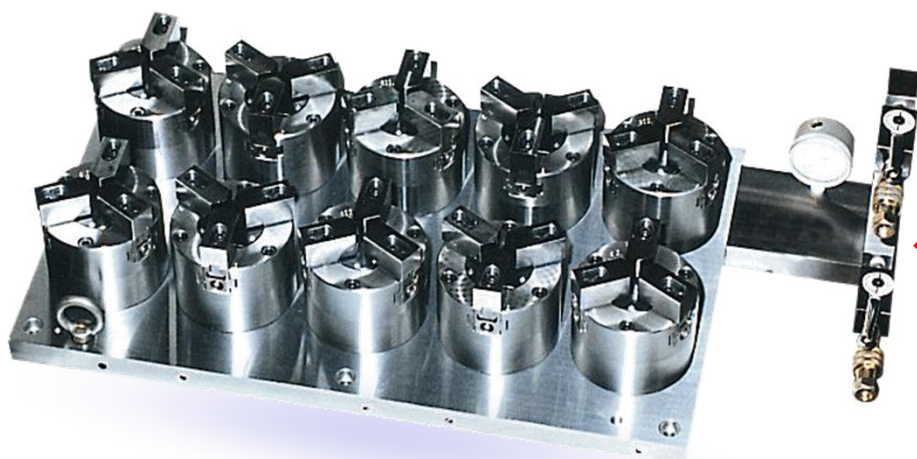
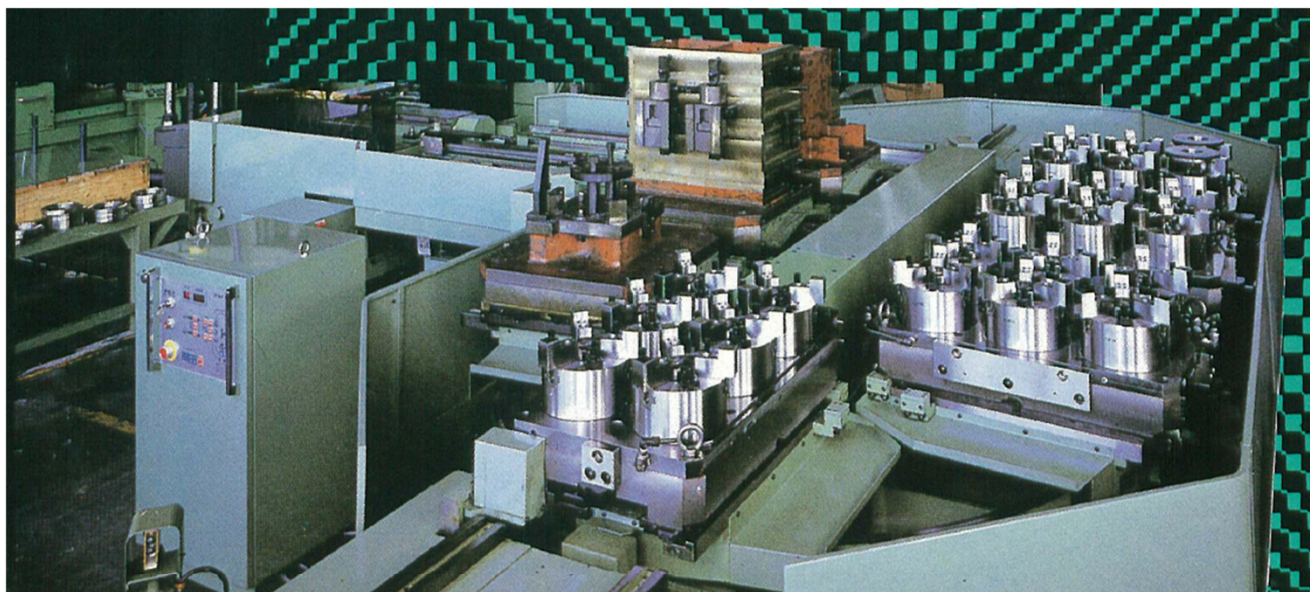

◆ **多連仕様も承ります。**

We also accept multiple specifications.

# CP

## 多連チャックパレット

Multiple chuck pallets



松本機械工業株式会社  
MATSUMOTO MACHINE CO., LTD.  
<https://mmkchuck.com>

〒920-0059 石川県金沢市示野町二80  
Ni-80 Shimeno-Machi Kanazawa, 920-0059 Japan  
Phone +81-(0)76-267-3211  
E-mail sales@mmkchuck.com  
ServiceCenter/Tokyo/Osaka/Nagoya/Tohoku  
Chicago, USA/Lyon, France

### 型式表示 Model display

# CP 00 - 0

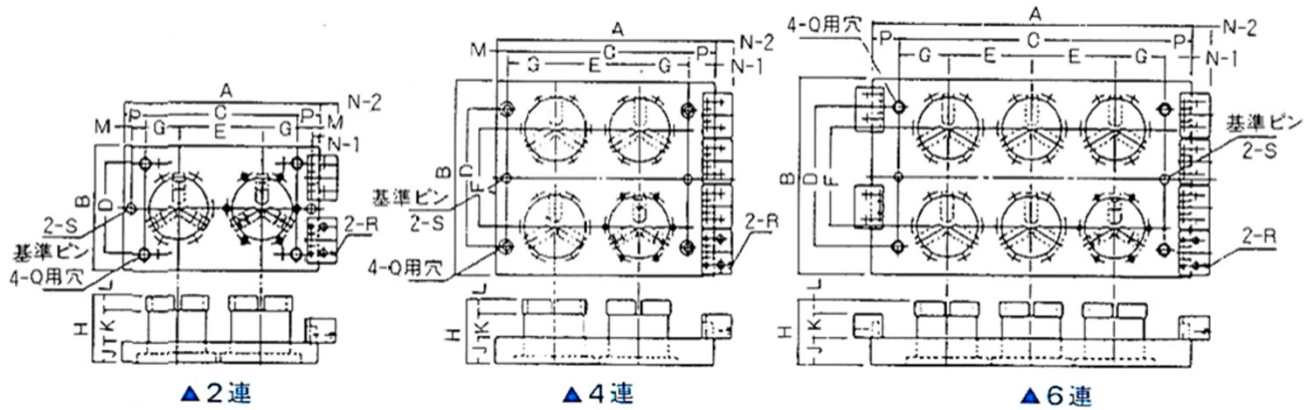
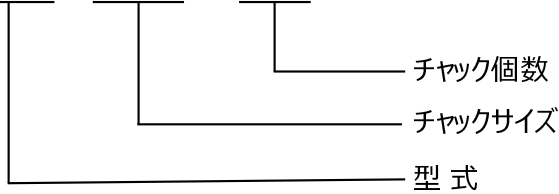

### 仕様&寸法 Specification & Size

型式	CP4-2	CP4-4	CP4-6	CP4-8	CP4-10	CP6-2	CP6-4	CP6-6	CP6-8	CP8-2	CP8-4	CP8-6	
仕様	2連	4連	6連	8連	10連	2連	4連	6連	8連	2連	4連	6連	
適応 STC	STC-4					STC-6					STC-8		
A	360	405	590	745	900	470	512	750	988	565	615	870	
B	220	350	350	350	415	245	470	470	470	315	535	535	
C	280	335	490	645	800	390	444	654	864	485	545	800	
D	160	250	250	250	250	160	250	250	250	250	250	250	
E	155	155	155	155	155	210	210	210	210	255	255	255	
F	-	175	175	175	175	-	245	245	245	-	260	260	
G	87.5	90	90	90	90	115	117	117	117	140	145	145	
H	118	118	118	118	118	127	127	127	127	148	148	148	
J	35	50	50	50	50	35	50	50	50	35	50	50	
K	53	38	38	38	38	56	41	41	41	71	56	56	
L	30	30	30	30	30	36	36	36	36	42	42	42	
M	15	20	-	-	-	15	20	-	-	15	20	-	
N-1	-2.5	-2.5	-2.5	-2.5	-2.5	-2.5	-2.5	-2.5	-2.5	-2.5	-2.5	-2.5	
N-2	32.5	32.5	32.5	32.5	32.5	32.5	32.5	32.5	32.5	32.5	32.5	32.5	
P	40	50	50	50	50	40	48	48	48	40	50	50	
Q	φ17	φ17	φ17	φ17	φ17	φ17	φ17	φ17	φ17	φ17	φ17	φ17	
R	PT1/4	PT1/4	PT1/4	PT1/4	PT1/4	PT1/4	PT1/4	PT1/4	PT1/4	PT1/4	PT1/4	PT1/4	
S	φ20	φ20	φ20	φ20	φ20	φ20	φ20	φ20	φ20	φ20	φ20	φ20	
重量 (kg)	14.5	36	52	68	84	17	55	79	103	26	67	150	
E	87	87	87	87	87	90	90	90	90	105	105	105	

改良に伴い仕様は予告なく変更されます。For the improvement, specifications will be changed without notice.